



ER Floating Chuck

Parallel floating for perfect holes

www.rego-fix.com

REGO-FIX 

Floating chucks

Floating chucks are practical problem solvers that have existed for over 100 years. Still these products are not very well known and continue to be of use on many modern machines. Below are the advantages of the floating chuck.

History of the floating chuck

Floating chucks are first mentioned in a patent of H. J. Watts of Turtle Creek, PA. The patent was filed as; FLOATING TOOL CHUCK, on November 30th, 1915 and granted September 25, 1917. It is not known how well the system worked or any units survived.

What is a floating chuck?

When using reamers on lathes it is often necessary to compensate for axis error between the chuck and the bore to be machined. This error can be corrected by using a self-centering floating chuck. The floating chuck perfectly adjusts the alignment between the reamer and the workpiece hole and ensures the same accuracy as the reamer itself.

What are the advantages of a floating chuck?

A unique self-centering mechanism eliminates "tapered & oversized" holes and improves the surface finish.

How does a floating chuck technically work?

A parallel floating mechanism compensates for misalignment between reamer and workpiece. A unique ball bearing and axle drive shaft structure allows both smooth vertical and horizontal operations under high torque in reaming. In certain machine tools such as semiautomatic lathes, swiss lathe machines or boring machines, it is difficult to use reamers properly for the execution of perfectly gauged bores having an excellent surface condition. This difficulty is due to a misalignment which, in the case of semiautomatic lathes, is due to an expansion of the headstock during operation and, in the case of swiss lathe machines, is generally due to wear.

What does this mean for you?

With faster reaming operations, the productivity will increase due to quality issues by the increased surface quality and bore precision. Tool life will also significantly increase because of symmetric reamer wear and tolerances are met for a longer production time.

Problems where the floating chuck always is beneficial:

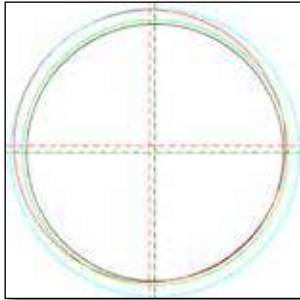

Misalignment | Problems

- // Original bore (black)
- // Reamer with radial error (red)
- // Reaming with radial error (blue)
- // Reaming with floating holder (green)



Bore becomes too large | Problems

- // Lack of cooling lubricant, formation of built-up edges
- // Irregularity of the cutting angle
- // Bore too small, friction tolerances too high
- // Axial offset between tool and pilot hole



Conical bore (entry too large) | Problems

- // Tool unstable in the axis
- // Pre-drilling not centered
- // Axial offset between tool and pilot hole
- // Chip formation in the upper bore area



Conical bore (end too large) | Problems

- // Axial offset between pre-bore and reamer axis
- // Chips in the lower hole area reamer pressing on hole bottom

Problems where the floating chuck always is beneficial:



Poor surface quality | Problems

- // Reamer or pilot hole damaged
- // Cooling lubricant missing
- // Poor chip removal
- // Misalignment between pre-bore and reamer axis



Reamer jams and breaks | Problems

- // Cylindrical grinding phase too wide
- // Cutting edge not conical enough
- // Predrilled hole too small and not centered
- // Angle of cut poorly ground



Hole shows chatter marks | Problems

- // Insufficient workpiece clamping
- // Too high cutting speed
- // Too low feed rate

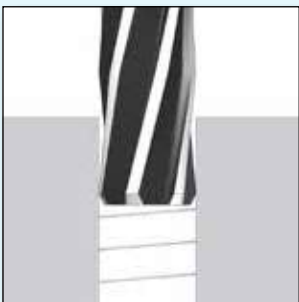

Retention marks in hole | Problems

- // Depth of cut
- // Use a sharper geometry
- // Pull back feed too high

ER floating chucks

When using reamers on lathes it is often necessary to compensate for axis error between the chuck and the bore to be machined. This error can be corrected by using a self-centering floating chuck.

PH/PHC/PHC-C/MPH/MPHC

Features and benefits

Adjustable floating resistance

Continuously adjustable between auto-centering and free-floating. No restriction of the floating movement.

Adjustment for tool weight

Optimal setup by adjustment of floating resistance is possible.

Vertical and horizontal application

Adjustable self-centering keeps the tool at the center of the floating chuck, even in the horizontal position. Prevents chatter marks and extends tool life.

Combined ball- and friction-bearing

Combined ball and friction-bearing for easy floating:

- // Ball bearing for smooth reaming at low load applications
- // Friction-bearing to withstand high pressures at high load applications

Double sealing against dirt

Prevents coolant and chips from entering the floating chuck.

Excellent bore quality

Only parallel floatation of tool possible.

Floating chuck PH/ER

Features REGO-FIX floating chucks are excellent tools for reaming and tapping:

- // They are specially designed so the tool is self-centering in a vertical and horizontal position
- // The self-centering feature allows very precise positioning of the reaming or tapping tool. This is especially important in horizontal applications, where on ordinary floating chucks the weight of the tool tends to dislocate the tool from the rotational axis
- // The float is always parallel to the rotational axis and the rotation is both clockwise and counter clockwise

Floating chuck PHC/ER for coolant through tools

Features Floating chucks PHC/ER for coolant through tools are especially designed for internal cooling and have the same advantages as the PH/ER floating chucks.

Floating chuck PHC-C/ER REGO-FIX CAPTO

Features These REGO-FIX CAPTO floating chucks are manufactured with polygon interface – licensed by Sandvik Coromant.

Floating chuck MPH/ERMX for tight spaces

Application REGO-FIX MPH/ERMX floating chucks are an efficient solution for tight space applications.

MPHC/ERMXC for tight spaces with internal cooling

Application The MPHC floating chuck is the mini version with internal cooling, common with modern reaming applications.

PH floating chucks for non coolant through tools

PH

Type	Art.-Nr.	Dimensions [mm]						Accessory
		D	D1 h6	D2	L	L1	G	Wrench
PH 5/8 [inch]								
PH 5/8" / ER 11	2616.91102	22	15,88	38	36	34	0,8	E 11 AX
PH 16 [mm]								
PH 16/ER 11	2616.91100	22	16	38	36	34	0,8	E 11 AX
PH 3/4 [inch]								
PH 3/4" / ER 11	2619.91102	22	19,05	38	36	34	0,8	E 11 AX
PH 20 [mm]								
PH 20/ER 11	2620.91100	22	20	38	36	34	0,8	E 11 AX
PH 22 [mm]								
PH 22/ER 11	2622.91100	22	22	38	36	34	0,8	E 11 AX

Included in delivery: Floating holder, HI-Q®/ER clamping nut and wrench.



In a conventional floating chuck, the centering of the tool. This centering process causes tool wear and can even lead to tool breakage.

The REGO-FIX floating chuck has an axis-parallel pendulum function that is self-centering. As a result, the tool is stable in the gating phase and no trumpet-shaped bore is created.

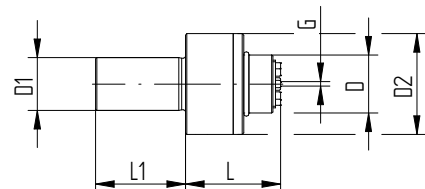

PH/ER

PHC floating chucks for coolant through tools

PHC

Type	Art.-Nr.	Dimensions [mm]						Accessory	
		D	D1 h6	D2	L	L1	G	Wrench	
PHC 5/8 [inch]									
PHC 5/8" / ER 20	2616.92004	33	15,88	56	53,5	38	1	E 20 AX	
PHC 16 [mm]									
PHC 16 / ER 20	2616.92003	33	16	56	53,5	38	1	E 20 AX	
PHC 3/4 [inch]									
PHC 3/4" / ER 20	2619.92004	33	19,05	56	53,5	38	1	E 20 AX	
PHC 3/4" / ER 32	2619.93204	46	19,05	70	64,5	46	1,5	E 32 AX	
PHC 20 [mm]									
PHC 20 / ER 20	2620.92003	33	20	56	53,5	38	1	E 20 AX	
PHC 20 / ER 32	2620.93203	46	20	70	64,5	46	1,5	E 32 AX	
PHC 22 [mm]									
PHC 22 / ER 20	2622.92003	33	22	56	53,5	38	1	E 20 AX	
PHC 22 / ER 32	2622.93203	46	22	70	64,5	46	1,5	E 32 AX	
PHC 25 [mm]									
PHC 25 / ER 20	2625.92003	33	25	56	53,5	38	1	E 20 AX	
PHC 25 / ER 32	2625.93203	46	25	70	64,5	46	1,5	E 32 AX	
PHC 1 [inch]									
PHC 1" / ER 20	2625.92004	33	25,4	56	53,5	38	1	E 20 AX	
PHC 1" / ER 32	2625.93204	46	25,4	70	64,5	46	1,5	E 32 AX	
PHC 1 1/4 [inch]									
PHC 1 1/4" / ER 32	2632.93204	46	31,75	70	64,5	46	1,5	E 32 AX	
PHC 32 [mm]									
PHC 32 / ER 32	2632.93203	46	32	70	64,5	46	1,5	E 32 AX	
PHC 1 3/4 [inch]									
PHC 1 3/4" / ER 32	2644.93204	46	44,45	70	64,5	46	1,5	E 32 AX	

Included in delivery: Floating holder, Hi-Q® / ERAX clamping nut, wrench and adjusting key.

Expert tip

When using internal coolant supply tools, special Hi-Q® / ERAXC locknuts and order appropriate sealing disks separately.

PHC-C floating chucks for coolant through tools with REGO-FIX CAPTO interface

PHC-C

Type	Part no.	Dimensions [mm]					G	Accessory
		D	D2	L	L1	Wrench		
PHC-C3								
PHC-C3 / ER 20	2803.92003	33	56	91	53,5	0,8	E 20 AX	
PHC-C4								
PHC-C4 / ER 20	2804.92003	33	56	91	56,5	0,8	E 20 AX	
PHC-C4 / ER 32	2804.93203	46	70	100	64	0,8	E 32 AX	

Included in delivery: Mini holder, Hi-Q® / ERMX nut and wreh

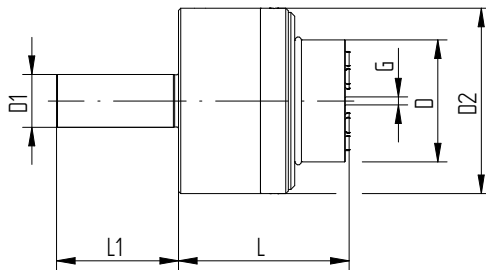

PHC/ER

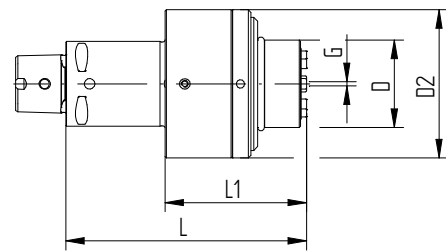

PHC-C/ER

Certified REGO-FIX CAPTO – licensed by Sandvik Coromant – is manufactured at REGO-FIX Switzerland under license according to CAPTO specifications.

MPH mini floating chucks with intrRlox® (slip-off proof mini nut)

Type	Part no.	Dimensions [mm]						Accessory	
		D	D1 h6	D2	L	L1	G	Wrench	
MPH 8 [mm]									
MPH 8/ERMX 11	4608.91107	16	8	25	35,5	42	0,5	E 11 MX	
MPH 10 [mm]									
MPH 10/ERMX 11	4610.91107	16	10	25	35,5	42	0,5	E 11 MX	
MPH 16 [mm]									
MPH 16/ERMX 11	4616.91107	16	16	25	35,5	42	0,5	E 11 MX	
MPH 3/4 [inch]									
MPH 3/4" /ERMX 11	4619.91108	16	19,05	25	35,5	70	0,5	E 11 MX	
MPH 20 [mm]									
MPH 20/ERMX 11	4620.91107	16	20	25	35,5	42	0,5	E 11 MX	
MPH 22 [mm]									
MPH 22/ERMX 11	4622.91107	16	22	25	35,5	42	0,5	E 11 MX	
MPH 25 [mm]									
MPH 25/ERMX 11	4625.91107	16	25	25	35,5	42	0,5	E 11 MX	
MPH 1 [inch]									
MPH 1" /ERMX 11	4625.91108	16	25,4	25	35,5	42	0,5	E 11 MX	

Included in delivery: Floating holder, Hi-Q® / ERMX clamping nut and wrench.

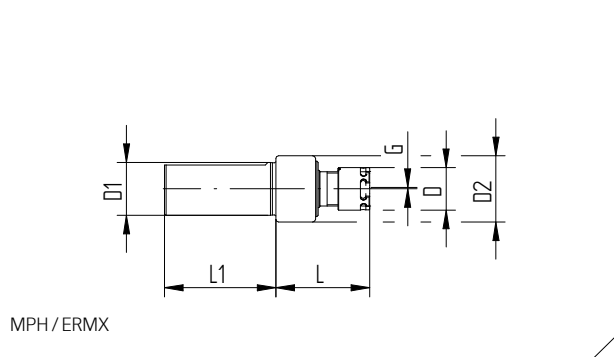

MPHC mini floating chucks with intrRlox® (slip-off proof mini nut)

MPHC

Typ	Part no.	Dimensions [mm]						Accessory	
		D	D1 h6	D2	L	L1	G	Wrench	
MPHC 8 [mm]									
MPHC 8 / ERMX 11	4608.91105	16	8	25	35,5	42	0,5	E 11 MX	
MPHC 10 [mm]									
MPHC 10 / ERMX 11	4610.91105	16	10	25	35,5	42	0,5	E 11 MX	
MPHC 10 / ERMX 16	4610.91605	22	10	31	47	42	0,5	E 16 MX	
MPHC 16 [mm]									
MPHC 16 / ERMX 16	4616.91605	22	16	31	47	42	0,5	E 16 MX	
MPHC 3/4 [inch]									
MPHC 3/4" / ERMX 11	4619.91106	16	19,05	25	35,5	42	0,5	E 11 MX	
MPHC 3/4" / ERMX 16	4619.91606	22	19,05	31	47	42	0,5	E 16 MX	
MPHC 20 [mm]									
MPHC 20 / ERMX 11	4620.91105	16	20	25	35,5	42	0,5	E 11 MX	
MPHC 20 / ERMX 16	4620.91605	22	20	31	47	42	0,5	E 16 MX	
MPHC 25 [mm]									
MPHC 25 / ERMX 16	4625.91605	22	25	31	47	42	0,5	E 16 MX	
MPHC 1 [inch]									
MPHC 1" / ERMX 16	4625.91606	22	25,4	31	47	42	0,5	E 16 MX	

Included in delivery: Mini holder, HI-Q® / ERMX nut and wrench

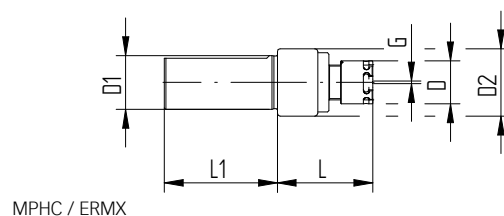

Finest quality deserves best treatment

Correct assembly increases your collet life and ensures low runout TIR.

Assembly instructions for ER and ER-UP collets

- // Insert collet groove into the eccentric ring of the clamping nut at the mark on the bottom of the nut
- // Push the collet in the direction of the arrow until it clicks in place
- // Screw the nut with the collet onto the colletcher
- // We recommend tightening the clamping nuts with our TORCO-BLOCK or torque wrench.

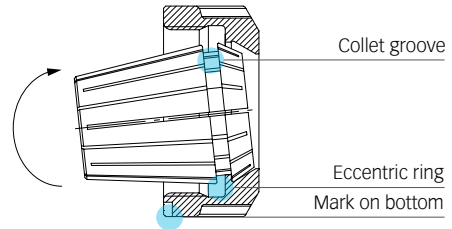

Assembling

Disassembly instructions After the nut is unscrewed from the colletcher, press on the face of the collet while simultaneously pushing sideways on the back of the collet opposite the mark until it disengages from the clamping nut.

General advice Never clamp oversized tool shanks. For example, never use a Ø 12 mm to 11 mm collet to clamp a Ø 12.2 mm shank. Rather use the next bigger collet (in this case a Ø 12.5 mm – 11.5 mm or 13 mm – 12 mm collet). Insert tool to the full length of the collet for best results if possible.

Also, never insert the tool less than $\frac{2}{3}$ of the collet length. Improper tool insertion can permanently deform the collet and will result in poor runout.

Improper assembly can permanently damage the runout TIR of the collet and may result in the destruction of the clamping nut. Only mount clamping nuts with correctly assembled collets.

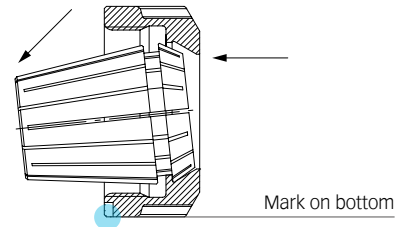

Disassembling

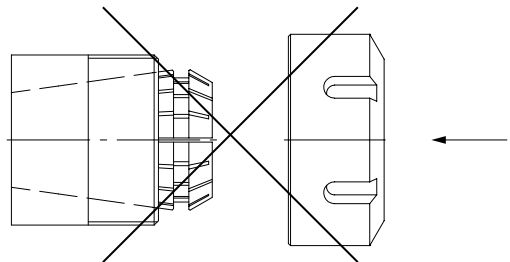

Expert advice

Please only set back-up screw to the tool shank **after** clamping the tool. Disregarding this will result in bad run out and reduced clamping force. The back-up screw only serves as protection against a push-back of the tool and must not be used for presetting.

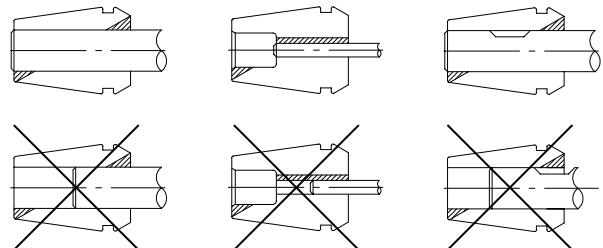

ER standard collets and Ultra-precision collets ER-UP

ER-Std.	ER-UP
DIN 6499-B	DIN 6499-B
ISO 15488	ISO 15488

Type	Part no.		clamping range		Ø [inch]	Included in the set
	ER-Standard	ER-UP	[mm]	[decimal inch]		
ER 11 [mm]						
SET ER 11	1111.00000	1111.00001	0,5–7,0	0,0197–0,2756	–	–
Ø 1.0 mm	1111.01000	1111.01001	1,0–0,5	0,0394–0,0197	1/32"	•
Ø 1.5 mm	1111.01500	1111.01501	1,5–1,0	0,0591–0,0394	–	•
Ø 2.0 mm	1111.02000	1111.02001	2,0–1,5	0,0787–0,0591	1/16"*	•
Ø 2.5 mm	1111.02500	1111.02501	2,5–2,0	0,0984–0,0787	3/32"*	•
Ø 3.0 mm	1111.03000	1111.03001	3,0–2,5	0,1181–0,0984	–	•
Ø 3.5 mm	1111.03500	1111.03501	3,5–3,0	0,1378–0,1181	1/8"*	•
Ø 4.0 mm	1111.04000	1111.04001	4,0–3,5	0,1575–0,1378	5/32"*	•
Ø 4.5 mm	1111.04500	1111.04501	4,5–4,0	0,1772–0,1575	–	•
Ø 5.0 mm	1111.05000	1111.05001	5,0–4,5	0,1969–0,1772	3/16"*	•
Ø 5.5 mm	1111.05500	1111.05501	5,5–5,0	0,2165–0,1969	–	•
Ø 6.0 mm	1111.06000	1111.06001	6,0–5,5	0,2362–0,2165	7/32"*	•
Ø 6.5 mm	1111.06500	1111.06501	6,5–6,0	0,2559–0,2362	1/4"*	•
Ø 7.0 mm	1111.07000	1111.07001	7,0–6,5	0,2756–0,2559	–	•
ER 16 [mm]						
SET ER 16	1116.00000	1116.00001	0,5–10,0	0,0197–0,3937	–	–
Ø 1.0 mm	1116.01000	1116.01001	1,0–0,5	0,0394–0,0197	1/32"	•
Ø 1.5 mm	1116.01500	1116.01501	1,5–1,0	0,0591–0,0394	–	–
Ø 2.0 mm	1116.02000	1116.02001	2,0–1,0	0,0787–0,0394	1/16"*	•
Ø 2.5 mm	1116.02500	1116.02501	2,5–1,5	0,0984–0,0591	3/32"*	–
Ø 3.0 mm	1116.03000	1116.03001	3,0–2,0	0,1181–0,0787	–	•
Ø 3.5 mm	1116.03500	1116.03501	3,5–2,5	0,1378–0,0984	1/8"*	–
Ø 4.0 mm	1116.04000	1116.04001	4,0–3,0	0,1575–0,1181	5/32"*	•
Ø 4.5 mm	1116.04500	1116.04501	4,5–3,5	0,1772–0,1378	–	–
Ø 5.0 mm	1116.05000	1116.05001	5,0–4,0	0,1969–0,1575	3/16"*	•
Ø 5.5 mm	1116.05500	1116.05501	5,5–4,5	0,2165–0,1772	–	–
Ø 6.0 mm	1116.06000	1116.06001	6,0–5,0	0,2362–0,1969	7/32"*	•
Ø 6.5 mm	1116.06500	1116.06501	6,5–5,5	0,2559–0,2165	1/4"*	–
Ø 7.0 mm	1116.07000	1116.07001	7,0–6,0	0,2756–0,2362	–	•
Ø 7.5 mm	1116.07500	1116.07501	7,5–6,5	0,2953–0,2559	9/32"*	–
Ø 8.0 mm	1116.08000	1116.08001	8,0–7,0	0,315–0,2756	5/16"*	•
Ø 8.5 mm	1116.08500	1116.08501	8,5–7,5	0,3346–0,2953	–	–
Ø 9.0 mm	1116.09000	1116.09001	9,0–8,0	0,3543–0,315	11/32"*	•
Ø 9.5 mm	1116.09500	1116.09501	9,5–8,5	0,374–0,3346	–	–
Ø 10.0 mm	1116.10000	1116.10001	10,0–9,0	0,3937–0,3543	3/8"*	•

ER standard collets and Ultra-precision collets ER-UP

ER-Std.	ER-UP
DIN 6499-B	DIN 6499-B
ISO 15488	ISO 15488

Type	Part no.		clamping range		Ø [inch]	Included in the set
	ER-Standard	ER-UP	[mm]	[decimal inch]		
ER 20 [mm]						
SET ER 20	1120.00000	1120.00001	1,0–13,0	0,0394–0,5118	–	–
Ø 1.0 mm	1120.01000	1120.01001	1,0–0,5	0,0394–0,0197	1/32"	–
Ø 1.5 mm	1120.01500	1120.01501	1,5–1,0	0,0591–0,0394	–	–
Ø 2.0 mm	1120.02000	1120.02001	2,0–1,0	0,0787–0,0394	1/16"	•
Ø 2.5 mm	1120.02500	1120.02501	2,5–1,5	0,0984–0,0591	3/32"	–
Ø 3.0 mm	1120.03000	1120.03001	3,0–2,0	0,1181–0,0787	–	•
Ø 3.5 mm	1120.03500	1120.03501	3,5–2,5	0,1378–0,0984	1/8"	–
Ø 4.0 mm	1120.04000	1120.04001	4,0–3,0	0,1575–0,1181	5/32"	•
Ø 4.5 mm	1120.04500	1120.04501	4,5–3,5	0,1772–0,1378	–	–
Ø 5.0 mm	1120.05000	1120.05001	5,0–4,0	0,1969–0,1575	3/16"	•
Ø 5.5 mm	1120.05500	1120.05501	5,5–4,5	0,2165–0,1772	–	–
Ø 6.0 mm	1120.06000	1120.06001	6,0–5,0	0,2362–0,1969	7/32"	•
Ø 6.5 mm	1120.06500	1120.06501	6,5–5,5	0,2559–0,2165	1/4"	–
Ø 7.0 mm	1120.07000	1120.07001	7,0–6,0	0,2756–0,2362	–	•
Ø 7.5 mm	1120.07500	1120.07501	7,5–6,5	0,2953–0,2559	9/32"	–
Ø 8.0 mm	1120.08000	1120.08001	8,0–7,0	0,315–0,2756	5/16"	•
Ø 8.5 mm	1120.08500	1120.08501	8,5–7,5	0,3346–0,2953	–	–
Ø 9.0 mm	1120.09000	1120.09001	9,0–8,0	0,3543–0,315	11/32"	•
Ø 9.5 mm	1120.09500	1120.09501	9,5–8,5	0,374–0,3346	–	–
Ø 10.0 mm	1120.10000	1120.10001	10,0–9,0	0,3937–0,3543	3/8"	•
Ø 10.5 mm	1120.10500	1120.10501	10,5–9,5	0,4134–0,374	13/32"	–
Ø 11.0 mm	1120.11000	1120.11001	11,0–10,0	0,4331–0,3937	–	•
Ø 11.5 mm	1120.11500	1120.11501	11,5–10,5	0,4528–0,4134	7/16"	–
Ø 12.0 mm	1120.12000	1120.12001	12,0–11,0	0,4724–0,433	15/32"	•
Ø 12.5 mm	1120.12500	1120.12501	12,5–11,5	0,4921–0,4528	–	–
Ø 13.0 mm	1120.13000	1120.13001	13,0–12,0	0,5118–0,4724	1/2"	•
ER 32 [mm]						
SET ER 32	1132.00000	1132.00001	2,0–20,0	0,0787–0,7874	–	–
Ø 2.0 mm	1132.02000	1132.02001	2,0–1,0	0,0787–0,0394	1/16"	–
Ø 2.5 mm	1132.02500	1132.02501	2,5–1,5	0,0984–0,0591	3/32"	–
Ø 3.0 mm	1132.03000	1132.03001	3,0–2,0	0,1181–0,0787	–	•
Ø 3.5 mm	1132.03500	1132.03501	3,5–2,5	0,1378–0,0984	1/8"*	–
Ø 4.0 mm	1132.04000	1132.04001	4,0–3,0	0,1575–0,1181	5/32"	•
Ø 4.5 mm	1132.04500	1132.04501	4,5–3,5	0,1772–0,1378	–	–
Ø 5.0 mm	1132.05000	1132.05001	5,0–4,0	0,1969–0,1575	3/16"*	•
Ø 5.5 mm	1132.05500	1132.05501	5,5–4,5	0,2165–0,1772	–	–

ER standard collets and Ultra-precision collets ER-UP

ER-Std.	ER-UP
DIN 6499-B	DIN 6499-B
ISO 15488	ISO 15488

Type	Part no.		clamping range		Ø [inch]	Included in the set
	ER-Standard	ER-UP	[mm]	[decimal inch]		
ER 32 [mm]						
Ø 6.0 mm	1132.06000	1132.06001	6,0–5,0	0,2362–0,1969	7/32"	•
Ø 6.5 mm	1132.06500	1132.06501	6,5–5,5	0,2559–0,2165	1/4"*	–
Ø 7.0 mm	1132.07000	1132.07001	7,0–6,0	0,2756–0,2362	–	•
Ø 7.5 mm	1132.07500	1132.07501	7,5–6,5	0,2953–0,2559	9/32"	–
Ø 8.0 mm	1132.08000	1132.08001	8,0–7,0	0,315–0,2756	5/16"*	•
Ø 8.5 mm	1132.08500	1132.08501	8,5–7,5	0,3346–0,2953	–	–
Ø 9.0 mm	1132.09000	1132.09001	9,0–8,0	0,3543–0,315	11/32"	•
Ø 9.5 mm	1132.09500	1132.09501	9,5–8,5	0,374–0,3346	–	–
Ø 10.0 mm	1132.10000	1132.10001	10,0–9,0	0,3937–0,3543	3/8"*	•
Ø 10.5 mm	1132.10500	1132.10501	10,5–9,5	0,4134–0,374	13/32"	–
Ø 11.0 mm	1132.11000	1132.11001	11,0–10,0	0,4331–0,3937	–	•
Ø 11.5 mm	1132.11500	1132.11501	11,5–10,5	0,4528–0,4134	7/16"*	–
Ø 12.0 mm	1132.12000	1132.12001	12,0–11,0	0,4724–0,4331	15/32"	•
Ø 12.5 mm	1132.12500	1132.12501	12,5–11,5	0,4921–0,4528	–	–
Ø 13.0 mm	1132.13000	1132.13001	13,0–12,0	0,5118–0,4724	1/2"*	•
Ø 13.5 mm	1132.13500	1132.13501	13,5–12,5	0,5315–0,4921	17/32"	–
Ø 14.0 mm	1132.14000	1132.14001	14,0–13,0	0,5512–0,5118	–	•
Ø 14.5 mm	1132.14500	1132.14501	14,5–13,5	0,5709–0,5315	9/16"*	–
Ø 15.0 mm	1132.15000	1132.15001	15,0–14,0	0,5906–0,5512	–	•
Ø 15.5 mm	1132.15500	1132.15501	15,5–14,5	0,6102–0,5709	19/32"	–
Ø 16.0 mm	1132.16000	1132.16001	16,0–15,0	0,63299–0,5906	5/8"*	•
Ø 16.5 mm	1132.16500	1132.16501	16,5–15,5	0,6496–0,6102	–	–
Ø 17.0 mm	1132.17000	1132.17001	17,0–16,0	0,6693–0,6299	21/32"	•
Ø 17.5 mm	1132.17500	1132.17501	17,5–16,5	0,689–0,6496	11/16"*	–
Ø 18.0 mm	1132.18000	1132.18001	18,0–17,0	0,7087–0,6693	–	•
Ø 18.5 mm	1132.18500	1132.18501	18,5–17,5	0,7283–0,689	23/32"	–
Ø 19.0 mm	1132.19000	1132.19001	19,0–18,0	0,748–0,7078	–	•
Ø 19.5 mm	1132.19500	1132.19501	19,5–18,5	0,7677–0,7284	3/4"*	–
Ø 20.0 mm	1132.20000	1132.20001	20,0–19,0	0,7874–0,748	25/32"	•
Ø 21.0 mm	1132.21000	1132.21001	21,0–20,0	0,8268–0,7874	13/16"*	–
Ø 22.0 mm	1132.22000	1132.22001	22,0–21,0	0,8661–0,8268	–	–

Included in the ER sets are all marked collets within that size and the matching collet tray ZWT.

* Approx. inch sizing

Type	Part no.	clamping range		Ø [inch]	Included in the set
		[mm]	[decimal inch]		
ER 11-DM [mm]					
Ø 3.0 mm	1211.03000	3,0–2,75	0,1181–0,1083	–	–
Ø 4.0 mm	1211.04000	4,0–3,75	0,1575–0,1476	–	–
Ø 5.0 mm	1211.05000	5,0–4,75	0,1969–0,187	–	–
Ø 6.0 mm	1211.06000	6,0–5,75	0,2362–0,2264	–	–
Ø 7.0 mm	1211.07000	7,0–6,75	0,2756–0,2657	–	–
ER 16-DM [mm]					
SET ER 16-DM	1216.00000	3,0–10,0	0,1181–0,3937	–	–
Ø 3.0 mm	1216.03000	3,0 h9	0,1181 h9	–	•
Ø 4.0 mm	1216.04000	4,0 h9	0,1575 h9	–	•
Ø 5.0 mm	1216.05000	5,0–4,5	0,1969–0,1772	–	•
Ø 6.0 mm	1216.06000	6,0–5,5	0,2362–0,2165	–	•
Ø 7.0 mm	1216.07000	7,0–6,5	0,2756–0,2559	–	•
Ø 8.0 mm	1216.08000	8,0–7,5	0,315–0,2953	–	•
Ø 9.0 mm	1216.09000	9,0–8,5	0,3543–0,3346	–	•
Ø 10.0 mm	1216.10000	10,0–9,5	0,3937–0,374	–	•
ER 20-DM [mm]					
SET ER 20-DM	1220.00000	3,0–13,0	0,1181–0,5118	–	–
Ø 3.0 mm	1220.03000	3,0 h9	0,1181 h9	–	•
Ø 4.0 mm	1220.04000	4,0 h9	0,1575 h9	–	•
Ø 5.0 mm	1220.05000	5,0 h9	0,1969 h9	–	•
Ø 6.0 mm	1220.06000	6,0 h9	0,2362 h9	–	•
Ø 7.0 mm	1220.07000	7,0–6,5	0,2756–0,2559	–	•
Ø 8.0 mm	1220.08000	8,0–7,5	0,315–0,2953	–	•
Ø 9.0 mm	1220.09000	9,0–8,5	0,3543–0,3346	–	•
Ø 10.0 mm	1220.10000	10,0–9,5	0,3937–0,374	–	•
Ø 11.0 mm	1220.11000	11,0–10,5	0,4331–0,4134	–	•
Ø 12.0 mm	1220.12000	12,0–11,5	0,4724–0,4528	–	•
Ø 13.0 mm	1220.13000	13,0–12,5	0,5118–0,4921	–	•



Type	Part no.	Clamping range		Ø [inch]	Incl. in set
		[mm]	[decimal inch]		
ER 32-DM [mm]					
SET ER 32-DM	1232.00000	6.0–20.0	0.2362–0.7874	–	–
Ø 6.0 mm	1232.06000	6.0 h9	0.2362 h9	–	•
Ø 7.0 mm	1232.07000	7.0 h9	0.2756 h9	–	–
Ø 8.0 mm	1232.08000	8.0–7.5	0.315–0.2953	–	•
Ø 9.0 mm	1232.09000	9.0–8.5	0.3543–0.3346	–	–
Ø 10.0 mm	1232.10000	10.0–9.5	0.3937–0.374	–	•
Ø 11.0 mm	1232.11000	11.0–10.5	0.4331–0.4134	–	–
Ø 12.0 mm	1232.12000	12.0–11.5	0.4724–0.4528	–	•
Ø 13.0 mm	1232.13000	13.0–12.5	0.5118–0.4921	–	–
Ø 14.0 mm	1232.14000	14.0–13.5	0.5512–0.5315	–	•
Ø 15.0 mm	1232.15000	15.0–14.5	0.5906–0.5709	–	–
Ø 16.0 mm	1232.16000	16.0–15.5	0.6299–0.6102	–	•
Ø 17.0 mm	1232.17000	17.0–16.5	0.6693–0.6496	–	–
Ø 18.0 mm	1232.18000	18.0–17.5	0.7087–0.689	–	•
Ø 19.0 mm	1232.19000	19.0–18.5	0.748–0.7283	–	–
Ø 20.0 mm	1232.20000	20.0–19.5	0.7874–0.7677	–	•

Expert advice

Please note that DM collets are not compatible with Weldon or Whistle notch shafts. To achieve internal cooling with Weldon or Whistle notch shafts, use the REGO-FIX sealing disks ER/DS with your REGO-FIX ER collet.

Hi-Q®/ERMX and Hi-Q®/ERMXC intRlox® Slip-off proof mini clamping nuts

Application

For use with REGO-FIX ER collet holders with mini thread and cylindrical holders.

Key advantages

- // Design is ideally suited for lathes and Swiss turning machines
- // Very slim sizing proofs suitable for machines where space is limited
- // Safe handling thanks to the patented intRlox® profile
- // Slip-off proof design with all advantages of the regular mini clamping nuts
- // Easy and safe clamping with the MX wrench

Application with sealing disk / coolant flush disk The Hi-Q®/ERMXC clamping nut is intended for use with the sealing disk system DS/ER and the coolant flush system KS/ER. The disk system allows the use of all standard ER collets, ultraprecision collets and tapping collets for coolant through tools.

- // Up to 150 bar coolant pressure
- // Prevents dirt and chips from entering the collet



Hi-Q®/ERMX

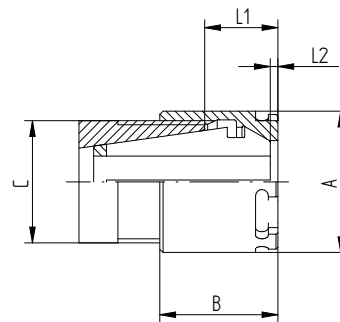

Hi-Q®/ERMX



Hi-Q®/ERMXC

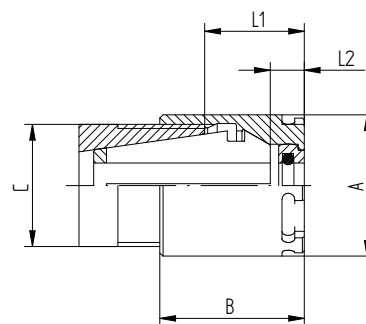

Hi-Q®/ERMXC

Hi-Q®/ERMX/ERMXC intRlox®

Type	Part no.	Dimensions [mm]					C	Accessory
		A	B	L1	L2	Wrench		
Hi-Q®/ERMX 11								
Hi-Q®/ERMX 11	3511.60000	16	12	5,7 – 7,5	0,4	M 13 x 0,75	E 11 MX	
Hi-Q®/ERMX 16	3516.60000	22	18,4	8 – 11,5	0,9	M 19 x 1	E 16 MX	
Hi-Q®/ERMXC 11	3511.70000	16	14,6	7,5 – 9,3	3,5	M 13 x 0.75	E 11 MX	
Hi-Q®/ERMXC 16	3516.70000	22	22	11,5 – 15	4,5	M 19 x 1	E 16 MX	

Hi-Q®/ERAX with external thread

Hi-Q®/ERAXC for coolant through tools

Application For REGO-FIX floating chucks and other ER collehoders with internal thread, e.g., ERA holders. These nuts can also be used on driven tools with internal threads.

Key advantages

- // Space-saving design for ideal use on long-turning machines
- // S-profile wrench is self-centering on the nut and prevents slipping off while tightening the nut

Application with sealing disk / coolant flush disk The Hi-Q®/ERAXC clamping nut is intended for use with the sealing disk system DS/ER and the coolant flush system KS/ER. The disk system allows the use of all standard ER collets, ultraprecision collets and tapping collets for coolant through tools.

- // Up to 150 bar coolant pressure
- // Prevents dirt and chips from entering the collet

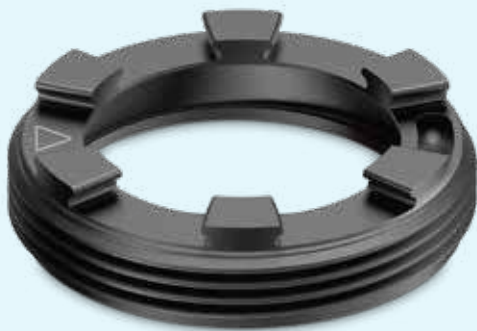

Hi-Q®/ERAX

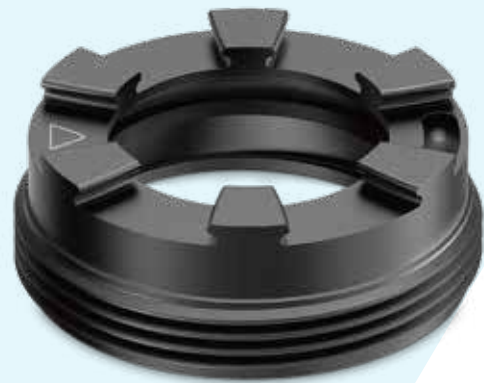

Hi-Q®/ERAXC

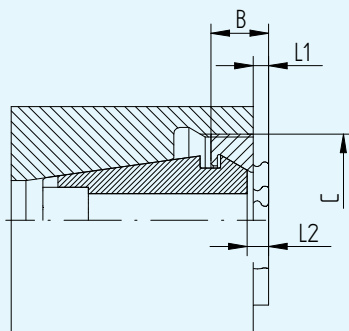

Hi-Q®/ERAX

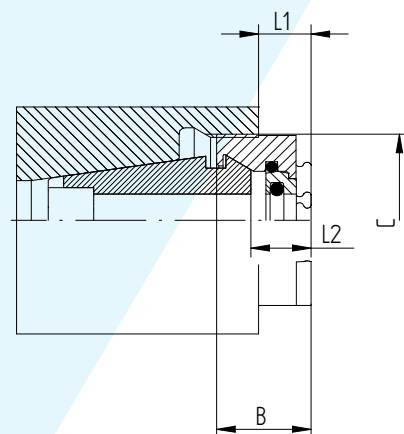

Hi-Q®/ERAXC

Hi-Q®/ERAX

Hi-Q®/ERAXC

ERAX

ERAXC

Type	Part no.	Dimensions [mm]			C	Accessory
		B	L1	L2		Wrench
Hi-Q®/ERAX 11						
Hi-Q®/ERAX 11	3311.60000	7,5	1,0-3,2	3,9	M 18 x 1	E 11 AX
Hi-Q®/ERAX 20						
Hi-Q®/ERAX 20	3320.60000	8,5	0-2,5	2,3	M 28 x 1,5	E 20 AX
Hi-Q®/ERAX 32						
Hi-Q®/ERAX 32	3332.60000	9,8	0-1,1	2,5	M 40 x 1,5	E 32 AX
Hi-Q®/ERAXC 11						
Hi-Q®/ERAXC 11	3311.70000	9,2	2,7-4,9	6,1	M 18 x 1	E 11 AX
Hi-Q®/ERAXC 20						
Hi-Q®/ERAXC 20	3320.70000	13,5	3,1-7,5	7,3	M 28 x 1,5	E 20 AX
Hi-Q®/ERAXC 32						
Hi-Q®/ERAXC 32	3332.70000	14,9	1,8-6,2	7,6	M 40 x 1,5	E 32 AX

Accessories are not included in delivery.

Affordable solution for internal cooling

Our sealing disks allow you to use your regular nonsealed collet for internal cooling, saving you acquisition costs for new collets.

Key advantages

Swiss quality product

Sealing range (excl. ER 11)

0.5 mm

High pressure

For applications up to 150 bar.

Protection

Protects against all kind of dirt and chips entering the slots of the collet.

Coolant resistant

O-ring for aggressive coolant (MITON®-quality).

Interchangeable

Quick change of sealing disks according to required tool shank diameter.

Coolant through

For better cooling and lubrication. Extends tool life and supports chip removal.

Matched tooling system for best fit

Our long-lasting machining experience results in a well-engineered system. All components are fitted together to one system to maximize your machining potential.

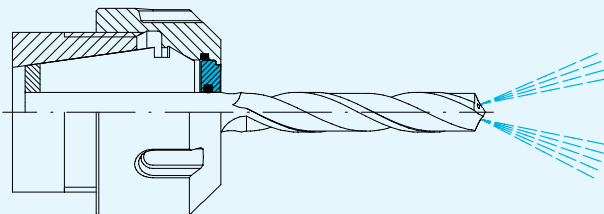

DS/ER

Finest quality deserves the best treatment

Correct assembly of the sealing disks DS/ER increases life and ensures low runout TIR.

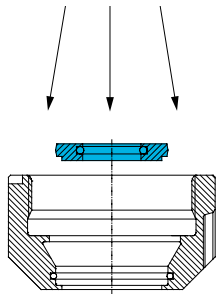

Assembling

Assembling Insert the small diameter of the disk into the center of the coolant nut. Apply an even pressure until the disk is properly seated into the nut.

The disk must be flush with the outside of the nut and the marking on the disk must be visible inside of the nut.

Removing To remove the disk, simply press on the outside of the disk evenly until it snaps out.

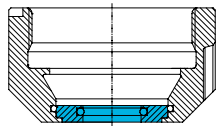

Inserted DS / ER

Expert advice

Insert tool with the shank side first. O-ring might be damaged if cutting tool is inserted from the back with the cutting edge side.

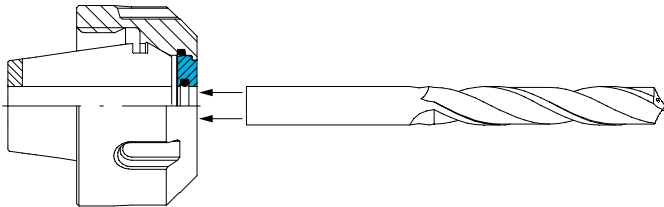

Insert tool

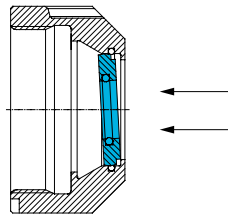

Disk removal

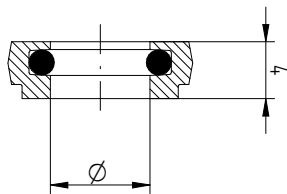

DS / ER

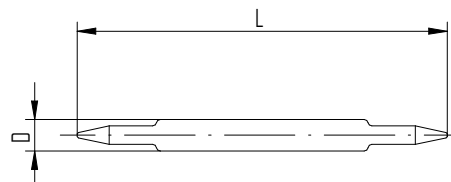

MWZ 11

Type	Part no.	D [mm]	L [mm]
MWZ 11 Assembly tool for sealing disk			
MWZ 11	3911.88888	12	140

Type	Part no.	Tool-Ø			Incl. in set
		Ø [inch]	[mm]	[decimal inch]	
DS / ER 11					
Ø 3.0 mm	3911.00300	–	3,0	–	–
Ø 1/8"	3911.00318	1/8"	–	–	–
Ø 4.0 mm	3911.00400	5/32"	4,0	–	–
Ø 3/16"	3911.00476	3/16"	–	–	–
Ø 5.0 mm	3911.00500	–	5,0	–	–
Ø 6.0 mm	3911.00600	–	6,0	–	–
Ø 1/4"	3911.00635	1/4"	–	–	–
BLANK DS / ER 11	3911.09999	–	–	–	–

Included in the DS/ER sets are all marked disks within that ER size and the matching disk try DSR. ER 11 has no sealing range, only for nominal use.

DS / ER 16					
DS / ER 16 SET (14 Stk. / pcs.)	3916.00000	–	3,0–10,0	0,1378–0,3937	–
Ø 3.0 mm	3916.00300	3/32"	3,0–2,5	0,1181–0,0984	–
Ø 3.5 mm	3916.00350	1/8"	3,5–3,0	0,1378–0,1181	•
Ø 4.0 mm	3916.00400	5/32"	4,0–3,5	0,1575–0,1378	•
Ø 4.5 mm	3916.00450	–	4,5–4,0	0,1772–0,1575	•
Ø 5.0 mm	3916.00500	3/16"	5,0–4,5	0,1969–0,1772	•
Ø 5.5 mm	3916.00550	7/32"	5,5–5,0	0,2165–0,1969	•
Ø 6.0 mm	3916.00600	–	6,0–5,5	0,2362–0,2165	•
Ø 6.5 mm	3916.00650	1/4"	6,5–6,0	0,2559–0,2362	•
Ø 7.0 mm	3916.00700	–	7,0–6,5	0,2756–0,2559	•
Ø 7.5 mm	3916.00750	9/32"	7,5–7,0	0,2953–0,2756	•
Ø 8.0 mm	3916.00800	5/16"	8,0–7,5	0,315–0,2953	•
Ø 8.5 mm	3916.00850	–	8,5–8,0	0,3346–0,315	•
Ø 9.0 mm	3916.00900	11/32"	9,0–8,5	0,3543–0,3346	•
Ø 9.5 mm	3916.00950	3/8"	9,5–9,0	0,374–0,3543	•
Ø 10.0 mm	3916.01000	–	10,0–9,5	0,3937–0,374	•
BLANK DS / ER 16	3916.09999	–	–	–	–

Included in the DS/ER sets are all marked disks within that ER size and the matching disk try DSR.

Type	Part no.	Tool-Ø			Incl. in set
		Ø [inch]	[mm]	[decimal inch]	
DS / ER 20					
SET DS / ER 20 (20 Stk. / pcs.)	3920.00000	–	3,0–13,0	0,1378–0,5118	–
Ø 3.0 mm	3920.00300	3/32"	3,0–2,5	0,1181–0,0984	–
Ø 3.5 mm	3920.00350	1/8"	3,5–3,0	0,1378–0,1181	•
Ø 4.0 mm	3920.00400	5/32"	4,0–3,5	0,1575–0,1378	•
Ø 4.5 mm	3920.00450	–	4,5–4,0	0,2165–0,1969	•
Ø 5.0 mm	3920.00500	3/16"	5,0–4,5	0,1969–0,1772	•
Ø 5.5 mm	3920.00550	7/32"	5,5–5,0	0,1772–0,1575	•
Ø 6.0 mm	3920.00600	–	6,0–5,5	0,2362–0,2165	•
Ø 6.5 mm	3920.00650	1/4"	6,5–6,0	0,2559–0,2362	•
Ø 7.0 mm	3920.00700	–	7,0–6,5	0,2756–0,2559	•
Ø 7.5 mm	3920.00750	9/32"	7,5–7,0	0,2953–0,2756	•
Ø 8.0 mm	3920.00800	5/16"	8,0–7,5	0,315–0,2953	•
Ø 8.5 mm	3920.00850	–	8,5–8,0	0,3346–0,315	•
Ø 9.0 mm	3920.00900	11/32"	9,0–8,5	0,3543–0,3346	•
Ø 9.5 mm	3920.00950	3/8"	9,5–9,0	0,374–0,3543	•
Ø 10.0 mm	3920.01000	–	10,0–9,5	0,3937–0,374	•
Ø 10.5 mm	3920.01050	13/32"	10,5–10,0	0,4134–0,3937	•
Ø 11.0 mm	3920.01100	–	11,0–10,5	0,433–0,4134	•
Ø 11.5 mm	3920.01150	7/16"	11,5–11,0	0,4528–0,4331	•
Ø 12.0 mm	3920.01200	15/32"	12,0–11,5	0,4724–0,4528	•
Ø 12.5 mm	3920.01250	–	12,5–12,0	0,4921–0,4724	•
Ø 13.0 mm	3920.01300	1/2"	13,0–12,5	0,5118–0,4921	•
BLANK DS / ER 20	3920.09999	–	–	–	–

Included in the DS/ER sets are all marked disks within that ER size and the matching disk try DSR.

Type	Part no.	Ø [inch]	[mm]	Tool-Ø Dimensions [mm]	Included in the set
DS / ER 32					
DS / ER 32 SET (34 Stk. / pcs.)	3932.00000	–	3,0–20,0	0,1181–0,7874	–
Ø 3.0 mm	3932.00300	3/32"	3,0–2,5	0,1181–0,0984	–
Ø 3.5 mm	3932.00350	1/8"	3,5–3,0	0,1378–0,1181	•
Ø 4.0 mm	3932.00400	5/32"	4,0–3,5	0,1575–0,1378	•
Ø 4.5 mm	3932.00450	–	4,5–4,0	0,1772–0,1575	•
Ø 5.0 mm	3932.00500	3/16"	5,0–4,5	0,1969–0,1772	•
Ø 5.5 mm	3932.00550	7/32"	5,5–5,0	0,2165–0,1969	•
Ø 6.0 mm	3932.00600	–	6,0–5,5	0,2362–0,2165	•
Ø 6.5 mm	3932.00650	1/4"	6,5–6,0	0,2559–0,2362	•
Ø 7.0 mm	3932.00700	–	7,0–6,5	0,2756–0,2559	•
Ø 7.5 mm	3932.00750	9/32"	7,5–7,0	0,2953–0,2756	•
Ø 8.0 mm	3932.00800	5/16"	8,0–7,5	0,315–0,2953	•
Ø 8.5 mm	3932.00850	–	8,5–8,0	0,3346–0,315	•
Ø 9.0 mm	3932.00900	11/32"	9,0–8,5	0,3543–0,3346	•
Ø 9.5 mm	3932.00950	3/8"	9,5–9,0	0,374–0,3543	•
Ø 10.0 mm	3932.01000	–	10,0–9,5	0,3937–0,374	•
Ø 10.5 mm	3932.01050	13/32"	10,5–10,0	0,4134–0,3937	•
Ø 11.0 mm	3932.01100	–	11,0–10,5	0,4331–0,4134	•
Ø 11.5 mm	3932.01150	7/16"	11,5–11,0	0,4528–0,4331	•
Ø 12.0 mm	3932.01200	15/32"	12,0–11,5	0,4724–0,4528	•
Ø 12.5 mm	3932.01250	–	12,5–12,0	0,4921–0,4724	•
Ø 13.0 mm	3932.01300	1/2"	13,0–12,5	0,5118–0,4921	•
Ø 13.5 mm	3932.01350	17/32"	13,5–13,0	0,5315–0,5118	•
Ø 14.0 mm	3932.01400	–	14,0–13,5	0,5512–0,5315	•
Ø 14.5 mm	3932.01450	9/16"	14,5–14,0	0,5709–0,5512	•
Ø 15.0 mm	3932.01500	–	15,0–14,5	0,5905–0,5709	•
Ø 15.5 mm	3932.01550	19/32"	15,5–15,0	0,6102–0,5906	•
Ø 16.0 mm	3932.01600	5/8"	16,0–15,5	0,6299–0,6102	•
Ø 16.5 mm	3932.01650	–	16,5–16,0	0,6496–0,6299	•
Ø 17.0 mm	3932.01700	21/32"	17,0–16,5	0,6693–0,6496	•
Ø 17.5 mm	3932.01750	11/16"	17,5–17,0	0,689–0,6693	•
Ø 18.0 mm	3932.01800	–	18,0–17,5	0,7087–0,689	•
Ø 18.5 mm	3932.01850	23/32"	18,5–18,0	0,7283–0,7087	•
Ø 19.0 mm	3932.01900	3/4"	19,0–18,5	0,748–0,7283	•
Ø 19.5 mm	3932.01950	–	19,5–19,0	0,7677–0,748	•
Ø 20.0 mm	3932.02000	25/32"	20,0–19,5	0,7874–0,7677	•
BLANK DS / ER 32	3932.09999	–	–	–	–

Included in the DS/ER sets are all marked disks within that ER size and the matching disk try DSR.

Our solution for peripheral cooling

The design of our coolant flush disks leads the coolant along the edge of the cutting tool, providing you with an easy way to achieve peripheral cooling.

Key advantages

Swiss quality product

Universal use

For all REGO-FIX collets and coolant nuts with interchangeable disk.

Interchangeable

Quick change of coolant flush disks according to required tool shank diameter.

Peripheral cooling

For better cooling and lubrication.
Extends tool life and supports chip removal.

Original REGO-FIX

Our long-lasting machining experience results in a well-engineered system. When buying ER coolant flush disks please pay attention to the REGO-FIX quality seal on the coolant flush disk: The triangle is our seal for outstanding quality made in Switzerland.

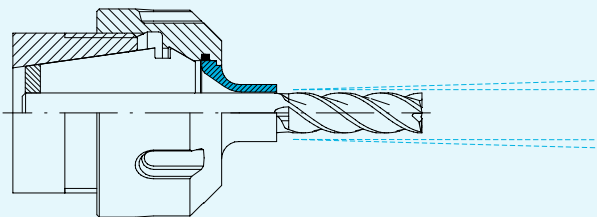

KS / ER

Type	Part no.	Dimensions [mm]			Ø	
		D	L	[mm]	[inch]	
KS / ER 11 [mm]						
Ø 3.0 mm / 1/8"	3911.30318	5,6	5,5	3	1/8"	
Ø 4.0 mm	3911.20400	6,4	5,5	4	–	
Ø 5.0 mm / 3/16"	3911.20500	7,5	5,5	5	3/16"	
Ø 6.0 mm / 1/4"	3911.30635	7,5	5,5	6	1/4"	
BLANK KS / ER 11 Ø 7.5 x 8	3911.29999	7,5	8	–	–	

* Work material: 42CrMoS4 (1.7227).

KS / ER 16 [mm]						
Ø 3.0 mm	3916.20300	6.4	11	3	–	
Ø 4.0 mm	3916.20400	7.4	11	4	–	
Ø 5.0 mm	3916.20500	8.4	11	5	–	
Ø 6.0 mm	3916.20600	9.4	11	6	–	
Ø 7.0 mm	3916.20700	11	11	7	–	
Ø 8.0 mm	3916.20800	11	11	8	–	
Ø 9.0 mm	3916.20900	11	2	9	–	
Ø 10.0 mm	3916.21000	11	2	10	–	
BLANK KS / ER 16 Ø 11 x 12*	3916.29999	11	12	–	–	

* Work material: 42CrMoS4 (1.7227).

KS / ER 20 [mm]						
Ø 3.0 mm	3920.20300	6,4	11	3	–	
Ø 4.0 mm	3920.20400	7,4	11	4	–	
Ø 5.0 mm	3920.20500	8,4	11	5	–	
Ø 6.0 mm	3920.20600	9,4	11	6	–	
Ø 7.0 mm	3920.20700	10,4	11	7	–	
Ø 8.0 mm	3920.20800	11,4	11	8	–	
Ø 9.0 mm	3920.20900	12,4	11	9	–	
Ø 10.0 mm	3920.21000	14	11	10	–	
Ø 12.0 mm	3920.21200	14	3	12	–	
BLANK KS / ER 20 Ø 14 x 12*	3920.29999	14	12	–	–	

* Work material: 42CrMoS4 (1.7227).

KS / ER 32 [mm]						
Ø 3.0 mm	3932.20300	6,4	11	3	–	
Ø 4.0 mm	3932.20400	7,4	11	4	–	
Ø 5.0 mm	3932.20500	8,4	11	5	–	
Ø 6.0 mm	3932.20600	9,4	11	6	–	
Ø 7.0 mm	3932.20700	10,4	11	7	–	
Ø 8.0 mm	3932.20800	11,4	11	8	–	
Ø 9.0 mm	3932.20900	12,4	11	9	–	
Ø 10.0 mm	3932.21000	13,4	11	10	–	
Ø 12.0 mm	3932.21200	15,4	11	12	–	
Ø 14.0 mm	3932.21400	17,4	11	14	–	
Ø 16.0 mm	3932.21600	19,4	11	16	–	
Ø 18.0 mm	3932.21800	21,4	11	18	–	
Ø 20.0 mm	3932.22000	24	11	20	–	
BLANK KS / ER 32 Ø 24 x 12*	3932.29999	24	12	–	–	

* Work material: 42CrMoS4 (1.7227).

Operating and maintenance instructions for floating chucks MPH/MPHC

Application of the floating chucks	Adjustment of the self-centering force
Standing application	For heavy tools, turn adjusting screw clockwise. For light tools, turn adjusting screw further to free floating.
Rotating application	Select stronger self-centering to avoid premature deflection by centrifugal forces.

Maintenance interval	Lubrication
Holder in use	every 2 working weeks
Holder not in use, but is located in tool changer of the machine.	every 2 working weeks
Holder not in use for a long time	before storage

Maintenance intervals depend on climatic and environmental conditions

⚠ Do not turn the adjusting screw all the way when floating function is required, always turn the adjusting screw one turn away from the stop.

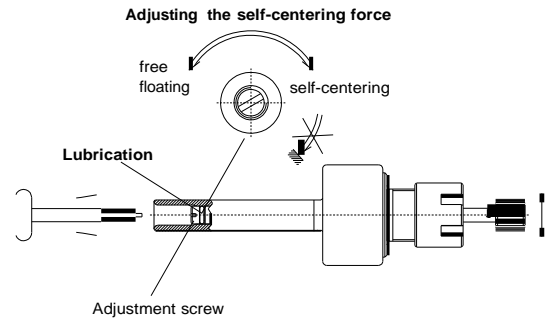

There are two main versions of floating chucks

MPHC



With 2 screws on the side of the flange.



1

Take both screws out with a fitting screwdriver (PH0). Blow out with dry pressurised air.



2

Put one screw back. Fill with 10 drops of oil.



3

Put the second screw back. Re-adjust the spring tension in the cylinder shaft.

MPH



With one screw in the cylindrical shaft on the back of the floating chuck.



1

Take the screw in the cylinder out with a fitting screwdriver (flat-head1). Blow out with dry pressurised air. Fill with 10 drops of oil.



2

Put the screw back in the back (do not forget the spring). Re-adjust the spring tension in the cylinder shaft.



036200208 Floatingchuck Brochure A4 EN

REGO-FIX 
www.rego-fix.com

REGO-FIX AG

Obermattweg 60
4456 Tenniken
Switzerland
info@rego-fix.com

// **REGO-FIX GERMANY**
Lörrach, DE 79539

// **REGO-FIX MEXICO**
Queretaro, MX 76903

// **REGO-FIX USA**
Whitestown, IN 46075

// **REGO-FIX INDIA**
Pune, IN 411038

// **REGO-FIX CHINA**
Shanghai, CN 201114

// **REGO-FIX MALAYSIA**
Johor Bahru, MA 81100

// **REGO-FIX BRAZIL**
18013-280 Sorocaba, SP

// **REGO-FIX INDONESIA**
Bojong Gede-Bogor, ID 16923